



OPTISENS TSS 3000 **Technical Datasheet**

Suspended solid sensor

- No optical windows
- Alternating light four beam technology
- Multiple path length for various concentration ranges

The documentation is only complete when used in combination with the relevant documentation for the signal converter.

1	Product features	3
<hr/>		
1.1	OPTISENS TSS 3000	3
1.2	Measuring principle.....	4
2	Technical data	6
<hr/>		
2.1	Technical data.....	6
2.2	Dimensions	7
3	Installation	8
<hr/>		
3.1	Intended use	8
3.2	Configuration of a measuring point	8
3.3	Installation procedure	8
4	Electrical connections	9
<hr/>		
4.1	Connecting the power supply to the signal converter MAC 300.....	9
4.2	Connecting the sensor cable to the signal converter	12
5	Order information	13
<hr/>		
5.1	Order code	13
6	Notes	14
<hr/>		

1.1 OPTISENS TSS 3000

The OPTISENS TSS 3000 sensor is manufactured using polypropylene (PP) as material. It features different sensor options with different path length between light source and detector for various measurement ranges.

With its alternating light 4 beam technology it improves the reliability of the sensor against the classic 2 beam technologies. It features 2 NIR LEDs (880nm) light sources and 2 detectors. With this technology it compensates for most errors due to dirt, aging of the detectors or even light source variations directly at the sensor itself.

No optical windows: The sensor feature a windowless design by measuring directly through the PP material layer. This means no problems due to window material and its different characteristics or resistance. With its 1 1/4" NPT thread it is easy adaptable to an immersion pipe or flanges for inline installation.

Highlights

- No optical windows
- Alternating light four beam technology
- 2x LEDs and 2x detectors
- Robust polypropylene body
- Multiple path length for various concentration ranges

Industries

- Water and waste water industry
- Food industry
- Chemical industry
- Metal and mining industry
- Pulp and paper industry

Applications

- Quality control in industrial and municipal wastewater applications
- Quality control and process monitoring in steam and cooling water circuits
- De-sludging of primary sedimentation (clarifier) tanks
- Monitoring biological treatment in wastewater aeration basins
- Heat exchanger monitoring (product leak detection into condensate/steam)
- Product loss monitoring in dairy factories

1.2 Measuring principle

The 4 beam alternating light principle compensates for variations in both light intensity and detector sensitivity. It features 2 light sources (LED's) which are switched on and off alternately and 2 detector.

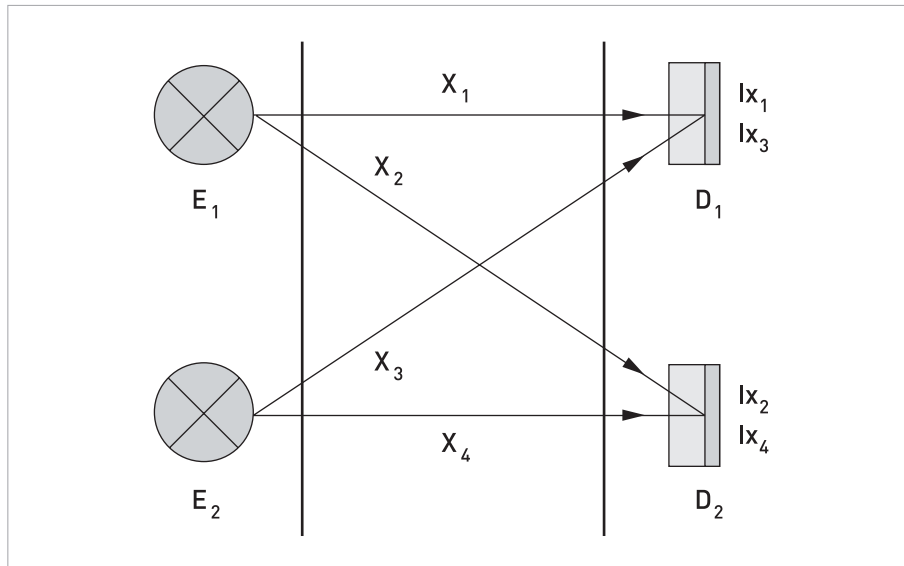

Figure 1-1: 2 lights and 2 detectors alternating light principle

When E_1 is turned 'ON' light is transmitted through the process media and each photodetector (D_1 and D_2) receives the light via paths X_1 and X_2 respectively. D_1 and D_2 generate signals based on the amplitude of light each photodetector receives. A ratio (R_a) is created by comparing these results.

$$R_a = I_{x_1}/I_{x_2} = 80\mu\text{A}/40\mu\text{A} = 2$$

Because any change in the characteristics of E_1 (due to age or contamination) will, affect D_1 and D_2 equally, this ratio will remain constant. For example, if the light output of E_1 is reduced by 25 %, the signals generated by D_1 and D_2 will both be reduced accordingly, but the ratio will remain the same. This eliminates the effects of contamination on E_1 .

$$R_a = I_{x_1}/I_{x_2} = 60\mu\text{A}/30\mu\text{A} = 2$$

The same procedure is performed using E_2 , across paths X_3 and X_4 and a similar ratio (R_b) is created. This eliminates the effects of contamination on E_2 .

$$R_b = I_{x_3}/I_{x_4} = 30\mu\text{A}/60\mu\text{A} = 0.5$$

To eliminate the effects of contamination or component aging on the detectors, a ratio comparing R_a and R_b is made.

$$R_a/R_b = 2/0.5 = 4$$

Because a change in the sensitivity of D_1 or D_2 (due to age or contamination) will reduce the light received from E_1 and E_2 equally, this ratio remains constant even if the characteristics of D_1 or D_2 change. For example if dirt covers 25% of D_1 , light received from both E_1 and E_2 will be reduced by 25 % but the ratio will remain the same.

$$R_a = I_{x_1}/I_{x_2} = 60\mu\text{A}/40\mu\text{A} = 1.5$$

$$R_b = I_{x_3}/I_{x_4} = 22.5\mu\text{A}/60\mu\text{A} = 0.375$$

$$R_a/R_b = 1.5/0.375 = 4$$

By using these ratios, rather than the direct output from D_1 and D_2 , the effects of contamination and component aging are eliminated.

Ambient light is detected by D_1 and D_2 while E_1 and E_2 are off. The resulting "offset" signal is used to correct the measurement. All signals are linearised and combined to produce a reliable 0/4...20mA output signal which is proportional to solids concentration.

By using single wavelength diodes with 880 nm which are outside the visible light spectrum the sensors are also insensitive to colour. KROHNE designs sensors of different sensitivity and measuring range by changing the distances between the sensor's light sources and detectors. When they are far apart, the sensor is more sensitive to suspended solids because the longer optical path lengths increase the sensor's ability to detect small changes in suspended solids concentration. However, because an increase in distance reduces the amount of detected light intensity, optical path length also determines the measuring range. For example, in two sensors with identical light sources, the sensor with longer path lengths will detect less light therefore it reaches the upper limit of its measuring range at a lower concentration and has a smaller measuring range. The sensor with shorter path lengths can measure higher concentrations and has a larger measuring range.

2.1 Technical data

- *The following data is provided for general applications. If you require data that is more relevant to your specific application, please contact us or your local sales office.*
- *Additional information (certificates, special tools, software,...) and complete product documentation can be downloaded free of charge from the website (Downloadcenter).*

Measuring system

Parameter	Suspended solids
Measuring principle	Transmitted light absorption principle; pulsed NIR 880 nm; with reference measurement. Reflection and absorption of light on suspended solids and sludge particles. The light passes the measured particles between the emitter and the detector in a straight line.

Design

Measuring scale	0...25 g/L with the path length 10 mm (Type 1)
	0...10 g/L with the path length 20 mm (Type 2)
	0...2.5 g/L with the path length 40 mm (Type 3)
Sensor thread	1 1/4" NPT

Operating conditions

Temperature range	0...85°C / +32...185°F
Pressure range	10 bar at 25°C / 145 psi at 77°F
Accuracy	± 2% of reading
Repeatability	± 1% of reading
Air pressure cleaning (Optional)	10 bar / 145 psi

Installation conditions

Ingress conditions	IP68
--------------------	------

Materials

Sensor body	PP - Polypropylene
Wetted material	
Cable gland sealing	NBR
Cable gland	PA
Cable	PU

Electrical connection

Cable	10 meter / 32.8 ft. (other lengths available)
-------	---

Approvals and certifications

CE
This device fulfils the statutory requirements of the EC directive. The manufacturer certifies successful testing of the product by applying the CE mark.
For full information of the EU directives and standards and the approved certifications, please refer to the EU declaration or the website of the manufacturer

2.2 Dimensions

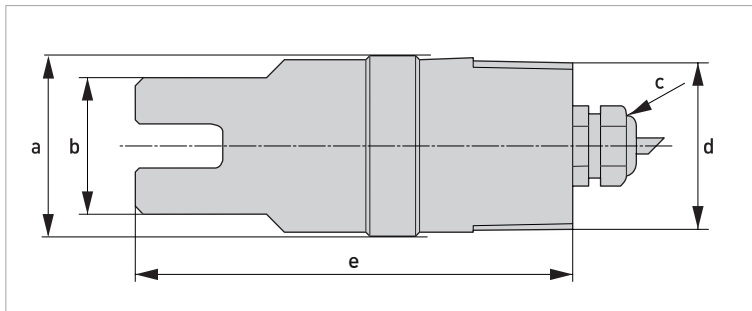

Figure 2-1: Dimensions

Type 1 (path length 10 mm)

	Dimensions [mm]	Dimensions [inch]
a	45 Max.	1.77 Max.
b	34	1.43
c		M20 x 1.5
d		1 1/4 NPT
e	110	4.33

Type 2 (path length 20 mm)

	Dimensions [mm]	Dimensions [inch]
a	45 Max.	1.77 Max.
b	43	1.69
c		M20 x 1.5
d		1 1/4 NPT
e	110	4.33

Type 3 (path length 40 mm)

	Dimensions [mm]	Dimensions [inch]
a	72 Max.	2.83 Max.
b	64	2.52
c		M20 x 1.5
d		1 1/4 NPT
e	122.3	4.81

3.1 Intended use

Responsibility for the use of the measuring devices with regard to suitability, intended use and corrosion resistance of the used materials against the measured fluid lies solely with the operator.

This device is a Group 1, Class A device as specified within CISPR11:2009. It is intended for use in industrial environment. There may be potential difficulties in ensuring electromagnetic compatibility in other environments, due to conducted as well as radiated disturbances.

The manufacturer is not liable for any damage resulting from improper use or use for other than the intended purpose.

The intended use of OPTISENS TSS 3000 sensors is the continuous on-line monitoring of suspended solids in industrial and municipal water and wastewater treatment plants, mining and refining operations. The sensor is suitable for connection to the MAC 300 signal converter.

3.2 Configuration of a measuring point

The sensor requires the external signal converter MAC 300 for setup, calibration and operation.

A complete measuring point consists of at least three parts:

- MAC 300 signal converter
- OPTISENS TSS 3000 sensor
- Immersion assembly or other adequate housing

3.3 Installation procedure

The sensor needs to be calibrated before it is installed into its final measuring location. To install the device in the correct way, follow the order and the following sections and their instructions.

1. Connect the sensor to the signal converter.
2. Calibrate the sensor.
3. Mount the sensor into the immersion assembly. (For further information refer to the manual of the assembly.)
4. Install the sensor into its final measuring location.

4.1 Connecting the power supply to the signal converter MAC 300

The device must be grounded in accordance with regulations in order to protect personnel against electric shocks.

Never install or operate the device in potentially explosive areas, it might cause an explosion that can result in fatal injuries!

When connecting the power supply, always note the safety regulations of the current state of the art. Also note the following items to avoid fatal injuries, destruction or damage of the device or measuring errors:

- *De-energise the cables of the power supply before you start any installation works!*
- *Always keep the housing of the device well closed if you do not perform any installation works. The function of the housing is to protect the electronic equipment from dust and moisture.*
- *Assure that there is a fuse protection for the infeed power circuit ($I_{nom} \leq 16 A$) and a disconnecting device (switch, circuit breaker) to isolate the signal converter.*
- *Check the nameplate and assure that the power supply meets the voltage and frequency of the device.
Universal 80-265 V AC or DC, 15 W max.
Low voltage option 18 – 32 V AC or DC, 20 W max.*
- *Assure that the protective earth conductor (PE) is longer than the L- and N-conductor.*

Wall mount (85-265V AC/DC)

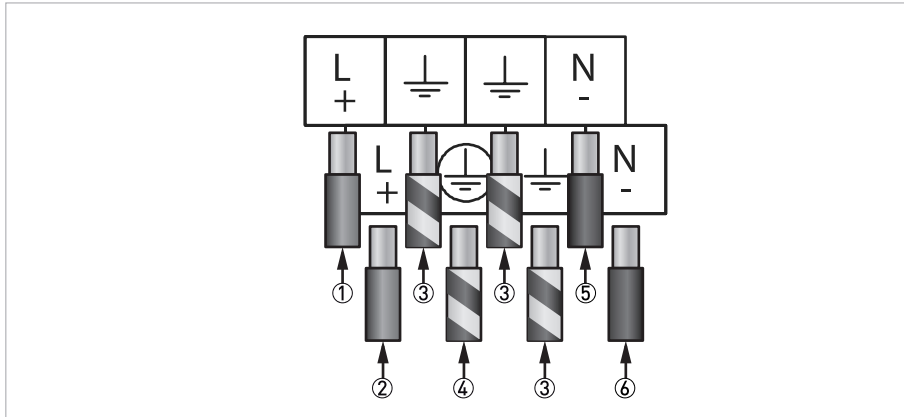

Figure 4-1: Power connector MAC 300 W

- ① Power supply "Live" out (for daisy chaining)
- ② Power supply "Live" in
- ③ Earth
- ④ Protective Earth (Must be connected)
- ⑤ Power supply "Neutral" out (for daisy chaining)
- ⑥ Power supply "Neutral" in

Wall mount (18-32V AC/DC)

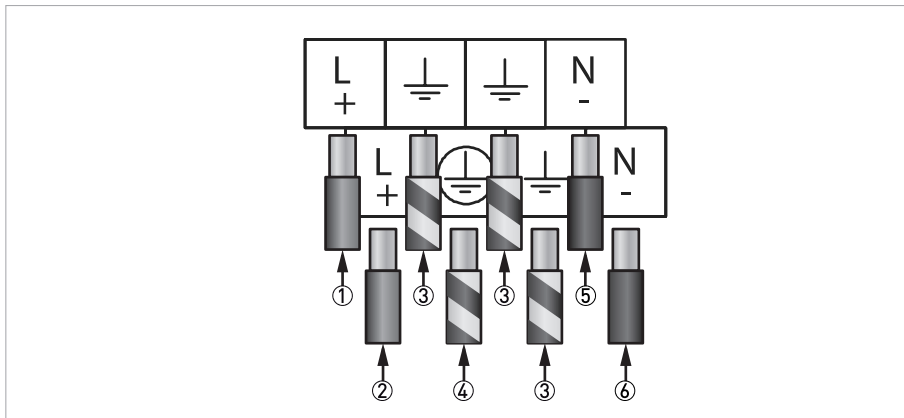

Figure 4-2: Power connector MAC 300 W

- ① Power supply "+" out (for daisy chaining)
- ② Power supply "+" in
- ③ Earth
- ④ Protective earth (Must be connected)
- ⑤ Power supply "-" out (for daisy chaining)
- ⑥ Power supply "-" in

Rack mount (85-265V AC/DC)

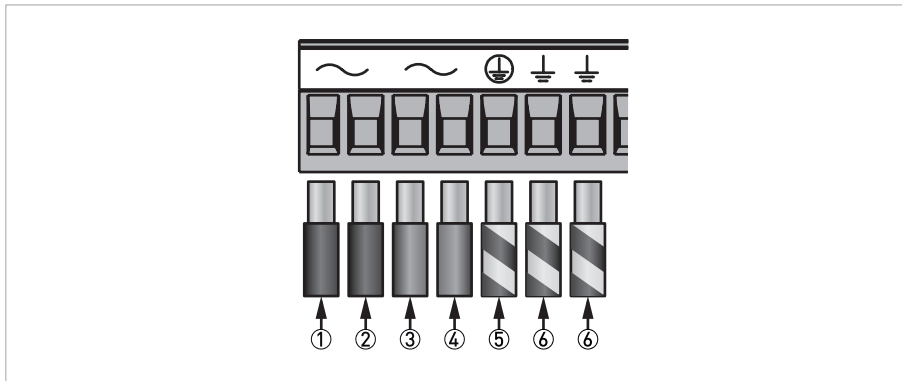

Figure 4-3: Main power connector MAC 300 R

- ① Power supply "Live" in
- ② Power supply "Live" out (for daisy chaining)
- ③ Power supply "Neutral" in
- ④ Power supply "Neutral" out (for daisy chaining)
- ⑤ Protective earth (must be connected)
- ⑥ Earth

Rack mount (18-32V AC/DC)

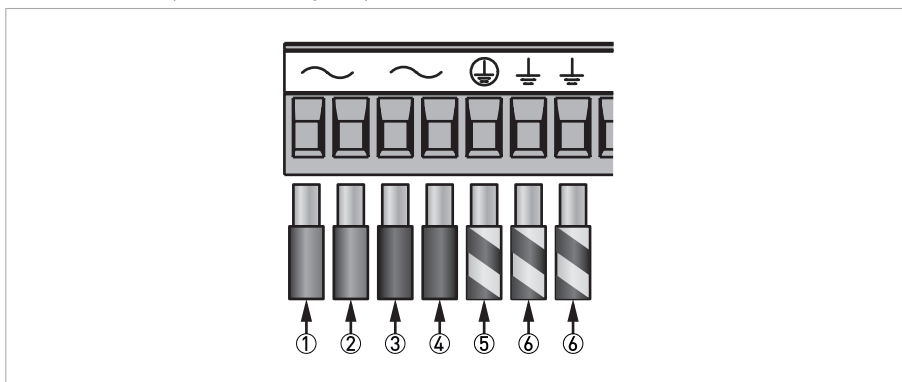

Figure 4-4: Main power connector MAC 300 R

- ① Power supply "+" in
- ② Power supply "+" out (for daisy chaining)
- ③ Power supply "-" in
- ④ Power supply "-" out (for daisy chaining)
- ⑤ Protective earth
- ⑥ Earth

To prevent destruction or damage, never operate the device outside of its permissible mechanical, thermal or chemical limits.

The power supply should be taken from an isolated spur and fused to a maximum of 3 Amps. If the relays require greater current, then a separate 5A fuse will be required. The incoming earth connection must be connected to the "Protective Earth" terminal.

4.2 Connecting the sensor cable to the signal converter

All work on the electrical connections may only be carried out with the power disconnected. Take note of the voltage data on the nameplate!

Connect the sensor to the MAC 300 for optimal configurability and process control due to following features:

- scale selection flexibility
- digital input to hold signals during cleaning process
- easy calibration via zero point and sensitivity adjustment
- set minimum and maximum for alarm relays
- galvanic isolated 4...20 mA outputs
- error current

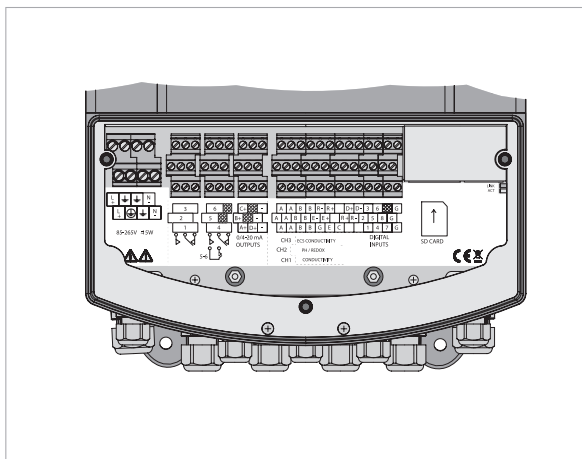

Figure 4-5: Overview terminal block MAC 300 W

Wall mount termination information

Suspended solids input connector								
Blue	Green	Red	Black	White	Brown	Orange	Yellow	Instrument earth stud
	↑	↑	↑	↑	↑	↑	↑	↑
	Green cable	Red cable	Black cable	White cable	Brown cable	Orange cable	Yellow cable	Cable screen

Rack mount termination information

Suspended solids input connector								
Blue	Green	Red	Black	White	Brown	Orange	Yellow	Earth terminal
	↑	↑	↑	↑	↑	↑	↑	↑
	Green cable	Red cable	Black cable	White cable	Brown cable	Orange cable	Yellow cable	Cable screen

5.1 Order code

The characters of the order code highlighted in light grey describe the standard.

VGA Y	4	Sensor type												
		3	OPTISENS TSS 3000											
			Wave length											
		2	880 nm											
			Optical path length (4 beam) / Measuring range											
		2	10 mm / approx. range 0...25 g/l, activated sludge 0...40% milk fat											
		3	20 mm / approx. range 0...10 g/l, activated sludge 0...20% milk fat											
		4	10 mm / approx. range 0...2.5 g/l, activated sludge 0...1.5% milk fat											
			Process conditions											
		2	0...+85°C, 10 bar / +32...+185°F, 145 psi											
			Body material											
		2	PP - Polypropylene											
			Optical window											
		0	None											
			Process connection											
		2	1 1/4 NPT (male) on cable side and immersion											
			Wetted sealing material											
		2	NBR, PA, PU											
			Cable length / connection											
		1	10 m hard wired core sleeve ends											
			Hygiene certificates											
		0	None											
			Approvals											
		0	None											
			Documentation											
		0	None											
		1	English											
		2	German											
		3	French											
		4	Spanish											
VGA Y	4													

Accessories for OPTISENS TSS 3000	Order code
Airjet cleaner for 10 mm sensor version	XGAY000010
Airjet cleaner for 20 mm sensor version	XGAY000020
Airjet cleaner for 40 mm sensor version	XGAY000030





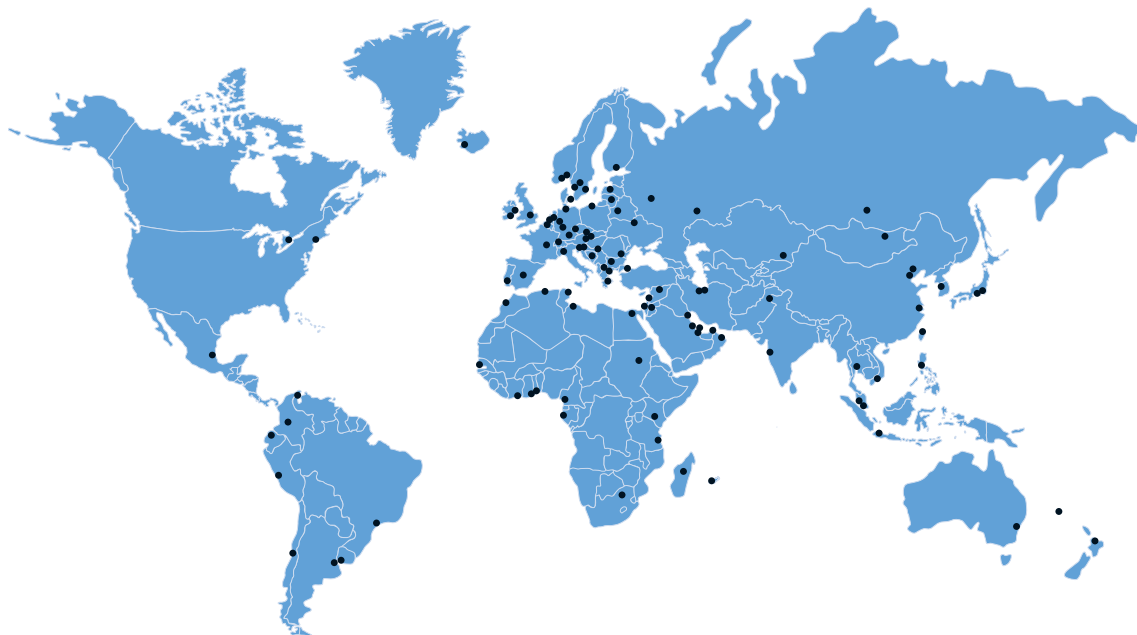

KROHNE – Process instrumentation and measurement solutions

- Flow
- Level
- Temperature
- Pressure
- Process Analysis
- Services

Head Office KROHNE Messtechnik GmbH
Ludwig-Krohne-Str. 5
47058 Duisburg (Germany)
Tel.: +49 203 301 0
Fax: +49 203 301 10389
info@krohne.com

The current list of all KROHNE contacts and addresses can be found at:
www.krohne.com

KROHNE