

Data sheet

Assisted lift operated 2/2-way solenoid valves

Type EV250B



EV250B with assisted lift can operate from zero and up to 10 bar differential pressure.

This 2/2-way valve program is especially to use in closed circuits with low differential pressure, but demanding moderate flow rates. Valve body in dezincification resistant brass for ensuring a long life even in connection with aggressive steam media.

EV250B is compatible with the broad Danfoss coil program with enclosures from IP00 up to IP67. Medium temperatures up to 140 °C (low pressure steam).

Features and versions:

- For water, oil, compressed air and similar neutral media
- Flow range: 0.5 – 20 m³/h
- Differential pressure: 0 – 10 bar
- Media temperature from -30 – 140 °C
- Ambient temperature: Up to 80 °C
- Coil enclosure: Up to IP67
- Thread connections: From G 3/8 – G 1
- DN 10 – 22
- Viscosity: Up to 50 cst
- The valve can be used for rough vacuum
- Water hammer damped
- DZR brass version in NC and NO
- Also available with NPT thread

Data sheet | Solenoid valves, type EV250B, dezincification resistant brass

DZR brass valve body, NC



Connection ISO228/1	Seal material	Orifice size	k _v - value [m ³ /h]	Differential pressure min. to max. [bar] / coil type ³⁾		Media temperature min. to max. [°C]	Code number
				BB/BE 10W AC BG 12 W AC BG 20W DC BN 20 W AC	BB/BE 18W DC ⁴⁾		
G 3/8	EPDM ¹⁾	10	2.5	0 – 10	0 – 6	-30 – 140	032U5250
	FKM ²⁾					0 – 100	032U5251
G 1/2	EPDM ¹⁾	12	4			-30 – 140	032U5252
	FKM ²⁾					0 – 100	032U5253
G 3/4	EPDM ¹⁾	18	6			-30 – 140	032U5254
	FKM ²⁾					0 – 100	032U5255
G 1	EPDM ¹⁾	22	7			-30 – 140	032U5256
	FKM ²⁾					0 – 100	032U5257

- 1) EPDM is suitable for water.
-30 – 120 °C: 0 – 10 bar
120 – 140 °C: 0 – 4 bar
- 2) FKM is suitable for oil and air. For water at max. 60 °C.
- 3) Pressure range can be extended to use in rough vacuum, typically up to 99% vacuum (10 mbar), depending on the application.
- 4) 6 bar max. opening differential pressure is measured at 6% undervoltage (22.6 V DC hot coil), 50 °C ambient and 90 °C media temperature.

DZR brass valve body, NO



Connection ISO228/1	Seal material	Orifice size	k _v - value [m ³ /h]	Differential pressure min. to max. [bar] / coil type		Media temperature min. to max. [°C]	Code number
				BB/BE 10W AC / 18W DC BG 12 W AC / 20W DC BN 20 W AC			
G 3/8	EPDM ¹⁾	10	2.5	0 – 10		-30 – 140	032U5350
	FKM ²⁾					0 – 100	032U5351
G 1/2	EPDM ¹⁾	12	4			-30 – 140	032U5352
	FKM ²⁾					0 – 100	032U5353
G 3/4	EPDM ¹⁾	18	4.9			-30 – 140	032U5354
	FKM ²⁾					0 – 100	032U5355
G 1	EPDM ¹⁾	22	5.2			-30 – 140	032U5356
	FKM ²⁾					0 – 100	032U5357

- 1) EPDM is suitable for water.
-30 – 120 °C: 0 – 10 bar
120 – 140 °C: 0 – 4 bar
- 2) FKM is suitable for oil and air. For water at max. 60 °C.

Data sheet | Solenoid valves, type EV250B, dezincification resistant brass

Technical data, NC and NO

Main type	EV250B 10BD	EV250B 12BD	EV250B 18BD	EV250B 22BD
Time to open [ms] ¹⁾	100	100	150	150
Time to close [ms] ¹⁾	100	100	100	100

¹⁾ The times are indicative and apply to water. The exact times will depend on the pressure conditions.

Installation	Vertical solenoid system is recommended		
Max. working pressure (MWP)	10 bar		
Max. test pressure (PT)	15 bar		
Tightness	Internally: Better than 0.4 mbar l/sec (25ccm air per min.) Externally: Better than 1* 10 ⁻³ mbar l/sec (100% He)		
Viscosity	Max. 50 cSt		
Materials	Valve body	DZR brass	CuZn36Pb2As/CZ 132
	Cover	Brass	W.no. 2.0402
	Armature	Stainless steel	W.no. 1.4105 / AISI 430 FR
	Armature tube	Stainless steel	W.no. 1.4306 / AISI 304 L
	Armature stop	Stainless steel	W.no. 1.4105 / AISI 430 FR
	Springs	Stainless steel	W.no. 1.4310 / AISI 301
	O-rings	EPDM or FKM	
	Valve plate	EPDM or FKM	
Diaphragm	EPDM or FKM		

Dimensions and weight: DZR brass, NC and NO

Type	Weight gross, valve body without coil [kg]	L [mm]	B [mm]	B ₁ [mm] / Coil type		H [mm]	H ₁ [mm]
				BB/BE	BG/BN		
EV250B 10	0.6	58	52.3	46	68	91	12.5
EV250B 12	0.6	58	52.3	46	68	91	12.5
EV250B 18	0.8	90.5	58	46	68	92	18
EV250B 22	1.1	90	58	46	68	96.3	22.3

Dimensions

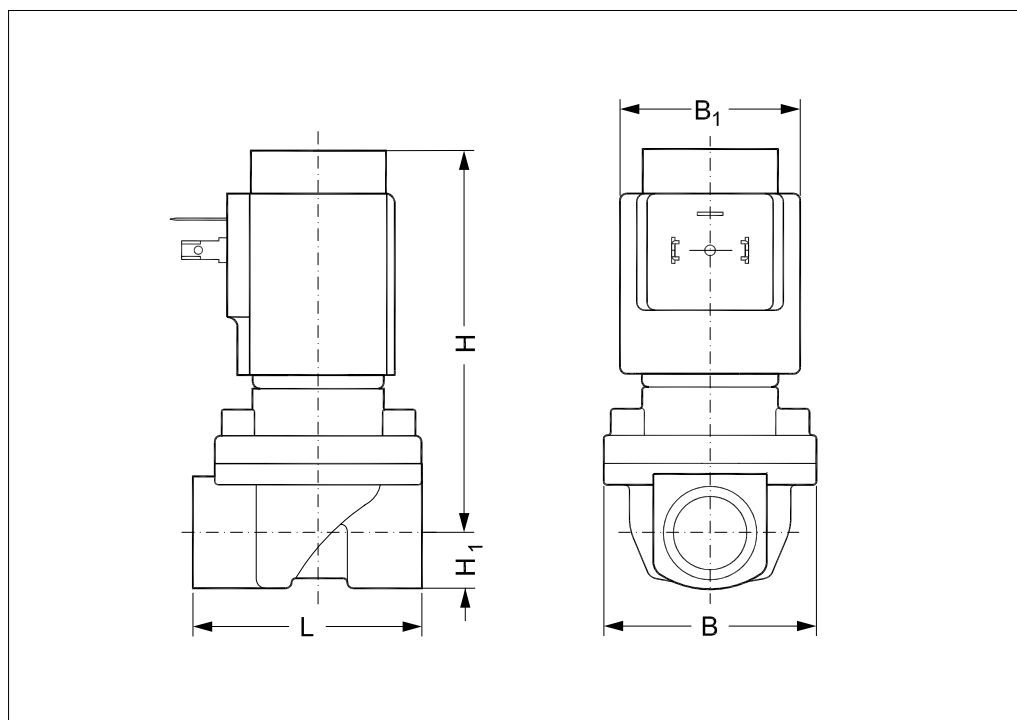

Mounting angle

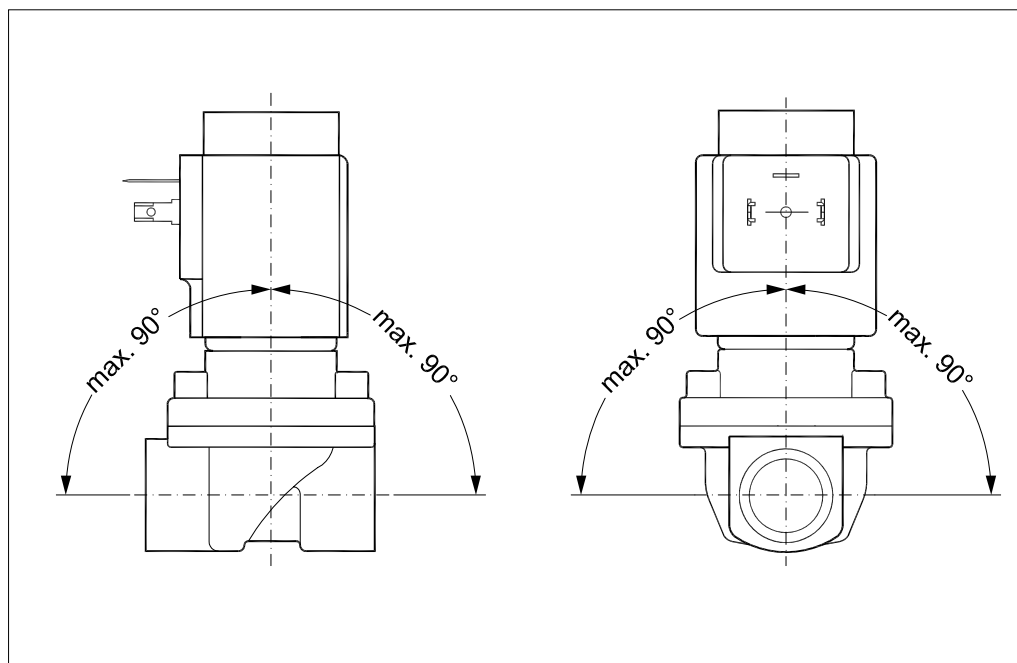

Data sheet | Solenoid valves, type EV250B, dezincification resistant brass

Below coils can be used with EV250B:

Coil	Type	Power consumption	Enclosure	Features
	BB, clip on	10 W AC 18 W DC	IP00 with spade connector	IP20 with protective cap, IP65 with cable plug
	BE, clip on	10 W AC 18 W DC	IP67	With terminal box
	BF, clip on	10 W AC 18 W DC	IP67	With 1 m cable
	BG, clip on	12 W AC 20 W DC	IP67	With terminal box
	BN, clip on	20 W 26 VA	IP67	Hum free With terminal box and 1 m cable

Universal electronic multi-timer, type ETM



Application	Voltage [V AC]	To use with coil	Ambient temperature [°C]	Code number
External adjustable timing from 1 to 45 minutes with 1 to 15 seconds drain open. With manual override (test button). Electrical connection DIN 43650 A / EN 175 301-803-A	24 – 240	BB	-10 – 50	042N0185

- Outside adjustments
- Light weight and small size
- External adjustable timing from 1 minute to 45 minutes with 1 to 15 seconds drain open
- One solid state timer fits all coil voltages from 24–240 V a.c
- Light diodes for indication
- All in one unit
- Manual override (test button)

Technical data

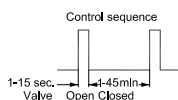

Type	ET 20 M
Voltage	24–240 V a.c / 50-60 Hz.
Power rating	Max. 20 Watt
Enclosure	IP00, IP65 with cable plug
Electrical connection	DIN connector (DIN 43650-A)
Ambient operating temperature range	-10 – 50 °C
Function	Start with pulse
Interval timer	1 – 45 min.
"On" timer	1 – 15 sec.
Weight	0.084 kg

Dimensions, ETM timer

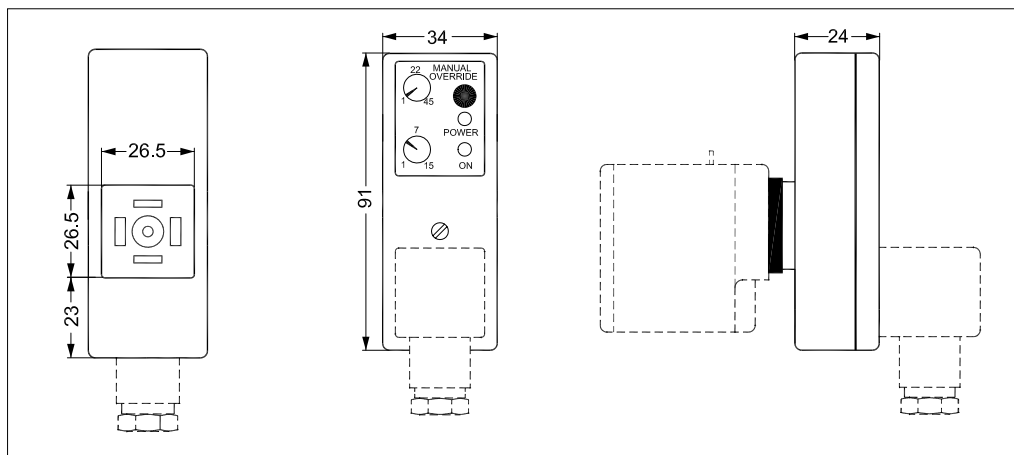

**Spare parts kit for NC
EPDM seal material**



For valve type	Seal material	Code number
EV250B 10 - 12BD	EPDM	032U5315
EV250B 18 - 22BD	EPDM	032U5317

The spare parts kit comprises:
 O-ring for coil
 4 screws
 Complete NC actuator unit with:
 Diaphragm
 Assist spring
 Armature
 Closing spring
 Cover
 Armature tube

**Spare parts kit for NC
FKM seal material**

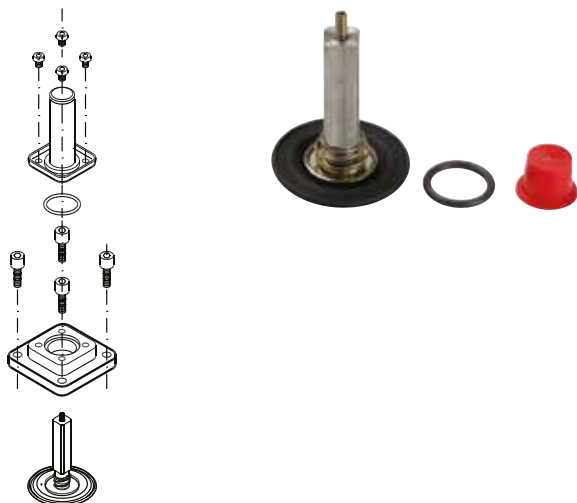

For valve type	Seal material	Code number
EV250B 10 - 12BD	FKM	032U5271
EV250B 18 - 22BD	FKM	032U5273

The spare parts kit comprises:
 O-ring
 Service element consisting of an armature with:
 Valve plate
 Spring fitted on the diaphragm

Spare parts kit for NO



For valve type	Seal material	Code number
EV250B 10 - 12BD	EPDM	032U5319
EV250B 10 - 12BD	FKM	032U5320
EV250B 18 - 22BD	EPDM	032U5321
EV250B 18 - 22BD	FKM	032U5322

The spare parts kit comprises:
 O-ring for coil
 4 screws
 Complete NO actuator unit with:
 Diaphragm
 Assist spring
 NO armature unit and cover

Function NC

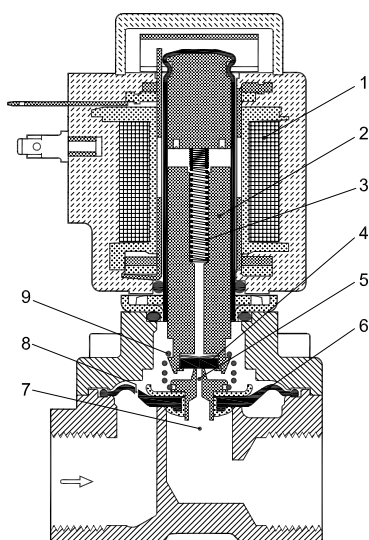

1. Coil
2. Armature
3. Closing spring
4. Valve plate
5. Pilot orifice
6. Diaphragm
7. Main orifice
8. Equalizing orifice
9. Assisted lift

Coil voltage disconnected (closed):

When the supply voltage to the coil (1) is disconnected, the valve plate (4) is pressed down against the pilot orifice (5) by the closing spring (3). The pressure across the diaphragm (6) is built up via the equalizing orifice (8). The diaphragm closes the main orifice (7) as soon as the pressure across the diaphragm is equivalent to the inlet pressure below, due to the larger diameter of the upper side and/or the tension of the closing spring (3). The valve will be closed as long as the voltage to the coil is disconnected.

Coil voltage connected (open):

When voltage is applied to the coil, the armature (2) and the valve plate (4) are lifted clear of the pilot orifice (5). If there is a differential pressure across the valve, the pressure above the diaphragm (6) drops as the pilot orifice is larger than the equalizing orifice. Therefore the diaphragm is lifted clear of the main orifice (7). If there is no differential pressure across the valve, the armature (2) draws the diaphragm (6) clear of the main orifice (7) using the assisted lift (9). The valve will be open for as long as there is voltage to the coil.

Function NO

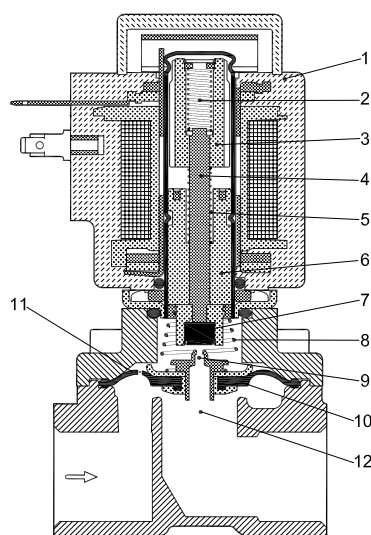

1. Coil
2. Closing spring
3. Armature
4. Spindle
5. Opening spring
6. Armature stop
7. Valve plate
8. Assisted lift
9. Pilot orifice
10. Diaphragm
11. Equalising orifice
12. Main orifice

Coil voltage disconnected (valve is open):

When the supply voltage to the coil (1) is disconnected, the valve plate (7) are lifted clear of the pilot orifice (9) if there is a differential pressure across the valve. The pressure above the diaphragm (10) drops as the pilot orifice is larger than the equalizing orifice. Therefore the diaphragm is lifted clear of the main orifice (12). If there is no differential pressure across the valve, the opening spring (5) draws the diaphragm (10) clear of the main orifice (12) using the assisted lift (8). The valve will be open for as long as there is no voltage to the coil.

Coil voltage connected (valve is closed):

When the supply voltage to the coil (1) is connected, the armature (3) will compress the opening spring (5) and the closing spring will push the spindle (4)/ valve plate down against the pilot orifice (9). The pressure across the diaphragm (10) is built up via the equalising orifice (11). The diaphragm closes the main orifice (12) as soon as the pressure across the diaphragm is equivalent to the inlet pressure below, due to the larger diameter of the upper side and / or the tension of the closing spring (2). The valve will be closed as long as coil voltage is connected.

Capacity diagram:

Example, water: EV250B 12
at differential pressure of 3 bar:
Approx. 7 m³/h

